

XTR Front Wheel WH-M975-Lefty

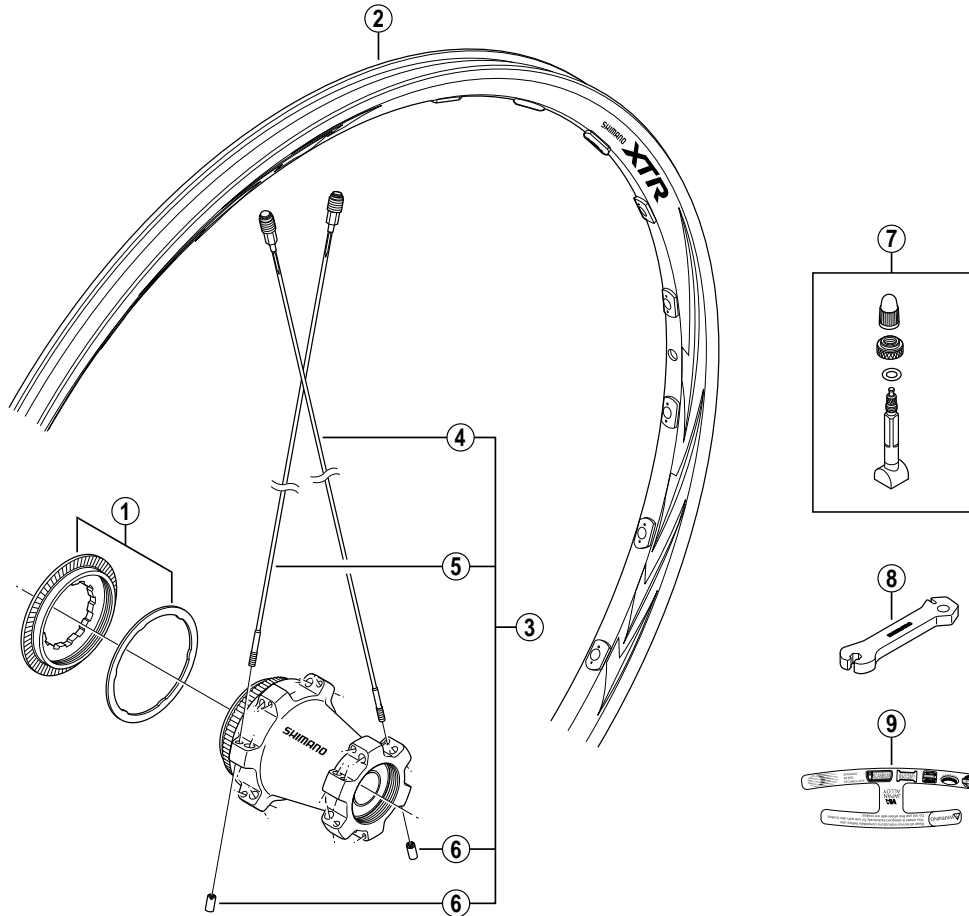

WH-M975
WH-M970

ITEM NO.	SHIMANO CODE NO.	DESCRIPTION	INTERCHANGEABILITY
1	Y-4E4 98010	Lock Ring & Washer	
2	I-WHRIM1BFDBD	Rim (24H / Black / Clincher (Tubuleless Type))	A
3	I-WHSPOKE1FB1	Spoke Unit (Spoke (272 mm x 12 pcs. & 270 mm x 12 pcs.) / Spoke Plug (24 pcs.) / Washer (24 pcs.) / Hub Nut (24 pcs.))	A
4	Y-4CK98010	Right Hand Spoke (272 mm) w/Plug & Washer	A
5	Y-4CK98020	Left Hand Spoke (270 mm) w/Plug & Washer	A
6	Y-4CK89000	Hub Nut	A A
7	Y-4CK98030	Valve Unit	A
8	Y-4CK19000	Spoke Plug Wrench	A A
9	Y-4E4 13000	Rim Sticker C	

A: Same parts.

B: Parts are usable, but differ in materials, appearance, finish, size, etc.

Absence of mark indicates non-interchangeability.

0708-2733

Specifications are subject to change without notice.

SHIMANO

General Safety Information

WARNING

- Check that the wheels are fastened securely before riding the bicycle. If the wheels are loose in any way, they may come off the bicycle and serious injury may result.
- Before use, check the wheels to make sure that there are no bent or loose spokes, dents, scratches or cracks on the rim surface. Do not use the wheel if any of these problems are found.
- The wheel is designed for cross-country riding. Do not use it for downhill riding, otherwise the wheel may become bent or otherwise damaged, and accidents may occur as a result.
- These wheels are designed exclusively for use with disc brakes. Do not use these wheels with rim brakes.
- Be sure to carefully read the Service Instructions for the disc brakes also.
- Obtain and read the service instructions carefully prior to installing the parts. Loose, worn, or damaged parts may cause injury to the rider. We strongly recommend only using genuine Shimano replacement parts.
- Read these Technical Service Instructions carefully, and keep them in a safe place for later reference.

CAUTION

- Do not use rim tape. Rim tape may make it difficult to remove and install the tire, and the tire or tube may become damaged or the tires may suddenly puncture and come off, and severe injury may result.

CAUTION

- Use genuine Shimano spokes, nuts, plugs and washers, otherwise damage to the rim and hub unit may result.
- The air pressure should be within the range of 200-400 kPa {29-58 psi}.
- Be careful not to overtighten the plugs when adjusting the spoke tensions. If the plugs are overtightened, damage to the rim may result. (We recommended that you ask authorized bicycle dealers to make the adjustments.)

Note

- Puncture repair agents and puncture prevention agents may corrode the rims, so only use neutral-type agents.
- Special spoke wrenches are available as optional accessories.
- We recommend that you ask authorized bicycle dealers to adjust the spoke tensions if there is any initial play in the spokes and after the first 1,000 km of riding.
- Do not use detergents or chemical cleaners to wipe the wheel, otherwise they may cause the air sealant that has been applied to the joints in the rim to peel off.
- Do not use detergent or other chemicals when wiping the wheel, otherwise it may cause the sticker on the rim to peel off.
- Reflectors are also sold separately. Please ask your bicycle dealer for details.

Model number	Specification	Color
RR-550-WUW SW W/O BRACKET	JIS / CPSC	White
RR-550-WUA SW W/O BRACKET	AS	Amber
RR-317-WUA SW W/O BRACKET	DIN	Amber

- For maximum performance we highly recommend Shimano lubricants and maintenance products.
- Parts are not guaranteed against natural wear or deterioration resulting from normal use.

Replacing the spokes

1. Pass the washer and plug over the spoke.
2. After inserting the spoke into the hole in the hub flange, tighten the nut. When installing, use the spoke stopper to secure the spoke so that it does not turn, and then insert a screwdriver or similar tool into the groove in the nut to screw in the nut.
3. Turn the plug clockwise to screw it into the screw hole in the rim. At this time, use the spoke stopper to stop the spoke from turning.

Note:

- If the washer is not installed, it will not be possible to adjust the spoke tension, so be sure to include the washer.
- Tighten the nut as far as the edges of the thread.

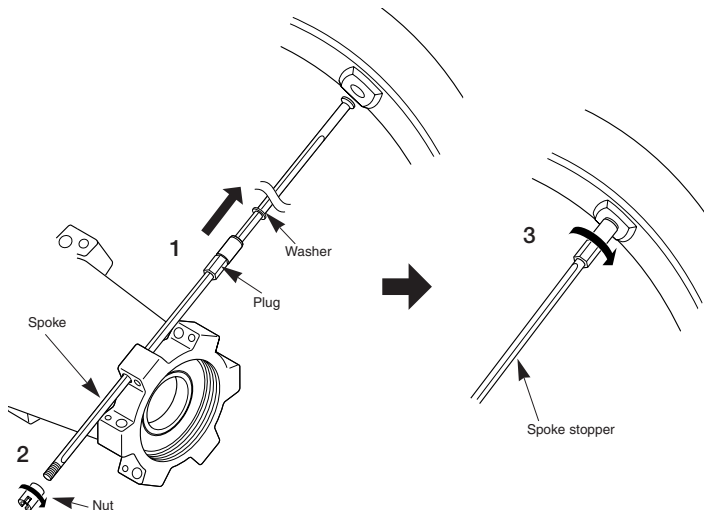

Spoke lacing

Lace the spokes as shown in the illustration.

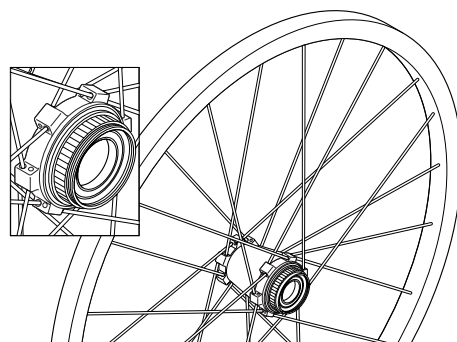

Spoke tension value	
Right side	Left side
600 - 1000 N (135 - 225 lbf)	900 - 1350 N (202 - 304 lbf)

* These values should be used as a guide only.

Technical Service Instructions

SI-4E40A-001

WH-M975

for "Lefty" front fork

Front Wheel

* Lefty is a registered trademark of Cannondale bicycle Corp.

In order to realize the best performance, we recommend that the following combination be used.

Rotor	SM-RT80 / SM-RT80S
-------	--------------------

Specifications

No. of spokes	24
Rim width	23.3 mm
Rim size	26"
Applicable tire size	26 x 1.5 ~ 2.25
Applicable brakes	Disc brake

Installation of the rotor

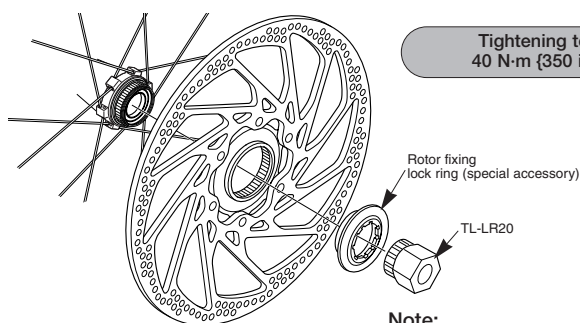

Tightening torque:
40 N·m {350 in. lbs.}

Note:
Use only the special Lefty accessory when installing.

SHIMANO

SHIMANO AMERICAN CORPORATION
One Holland, Irvine, California 92618, U.S.A. Phone: +1-949-951-5003

SHIMANO EUROPE B.V.
Industrieweg 24, 8071 CT Nunspeet, The Netherlands Phone: +31-341-272222

SHIMANO INC.
3-77 Oimatsu-cho, Sakai-shi, Osaka 590-8577, Japan

These service instructions are printed on recycled paper.
Please note: specifications are subject to change for improvement without notice. (English)
© Apr. 2007 by Shimano Inc. XBC SZK Printed in Japan.