

## TANDEM

- Die ultraleichten und extreme biegesteifen Oversized-Aluminiumrohre sind perfekt für's Tandem
- Geeignet für Fegenbremsen und/ oder Scheibenbremsen, wenn die Portion Extra-Bremskraft benötigt wird
- Das spezielle Tretlagergehäuse ist fuer die Aufnahme des patentierten Exzenters mit Doppelkeilbefestigung ausgelegt. Dadurch schnelle und einfache Einstellung der Kettenspannung
- Montagemöglichkeit für 4 Flaschenhalter
- Die Alu-Gabelholme der Fatty-Rigid sind Scheibenbremsen kompatibel.  
Sie sind ausserdem so stabil und präzise, dass sie die besondere Belastung eines Tandems klaglos überstehen

## GRÖSSEN

Road: M/S, L/S, X/S, J/M

Mountain/Touring: M/S, L/S, X/S, X/M

## GARANTIE

Lebenslange Garantie auf den Rahmen für den Erstbesitzer

[www.cannondale.com](http://www.cannondale.com)

TANDEM

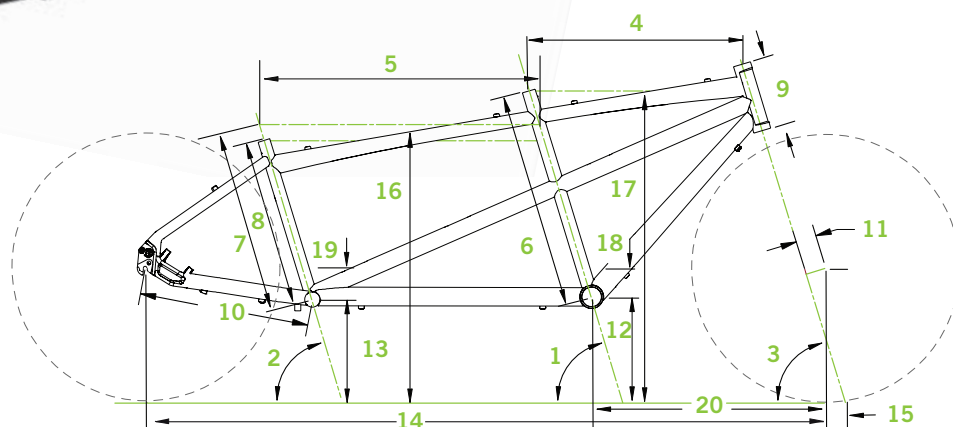

SIZE	TANDEM ROAD 700C				TANDEM MOUNTAIN/TOURING 26"				
	M/S	L/S	X/S	J/M	M/S	L/S	X/S	X/M	
1	Front Seat Tube Angle (degrees)	73	*	*	*	73	*	*	*
2	Rear Seat Tube Angle (degrees)	73	*	*	*	73	*	*	*
3	Head Tube Angle (degrees)	73	*	*	*	71	*	*	*
4	Horizontal Front Top Tube Length (in/cm)	43/109	11/28	226/575	59/150	225/571	46/117	59/150	246/625
5	Horizontal Rear Top Tube Length (in/cm)	13/33	13/33	13/33	291/739	13/33	13/33	13/33	291/739
6	Front Seat Tube Overall Length (in/cm)	190/483	50/127	220/559	115/292	180/457	190/483	210/533	220/559
7	Rear Seat Tube Overall Length (in/cm)	85/216	85/216	85/216	190/483	85/216	85/216	85/216	190/483
8	Rear Seat Tube Measured Length (in/cm)	156/397	156/397	85/216	190/483	156/397	156/397	85/216	190/483
9	Headtube Length (in/cm)	59/150	13/33	71/180	79/200	59/150	13/33	71/180	79/200
10	Chainstay Length (in/cm)	87/221	*	*	*	87/221	*	*	*
11	Fork Rake (in/cm)	21/53	*	*	*	21/53	*	*	*
12	Front Bottom Bracket Height (in/cm)	54/137	*	*	*	115/292	*	*	*
13	Rear Bottom Bracket Height (in/cm)	35/89	*	*	*	112/285	*	*	*
14	Wheelbase (in/cm)	171/434	199/505	390/991	355/902	124/315	363/922	80/203	245/622
15	Trail (in/cm)	20/51	*	*	*	23/58	*	*	*
16	Front Standover at Top Tube midpoint (in/cm)	94/239	102/259	316/803	325/826	46/117	149/379	103/262	159/404
17	Rear Standover at Top Tube midpoint (in/cm)	127/323	263/668	46/117	59/148	257/652	264/673	139/353	293/744
18	Front Bottom Bracket Drop (in/cm)	29/74	*	*	*	15/38	*	*	*
19	Rear Bottom Bracket Drop (in/cm)	32/81	*	*	*	9/23	*	*	*
20	Front Center Distance (in/cm)	229/583	235/597	241/612	251/637	249/632	255/647	261/664	136/345